



china eu india japan korea russia usa

Modeling development for control for ITER advanced scenarios

T. A. Casper¹, D. Campbell¹, Y. Gribov¹, S.H. Kim¹, W.H. Meyer²,
J. Oikawa¹, L.D. Pearlstein², A. Polevoi¹, J.A. Snipes¹, and L. Zabeo¹

¹ *ITER Organization, Route de Vinon sur Verdon, 13115 St Paul Lez Durance, France*

² *Lawrence Livermore National Laboratory, P.O. Box 808, Livermore, CA USA 94550*

European Physical Society

38th Conference on Plasma Physics

17th June – 1st July 2011

Strasbourg, France

Abstract

The final design of the ITER PF/CS coils converged after recent design reviews leading up to the start of construction. Significant effort has been spent on modeling details of the baseline 15MA inductive discharge [1, 2] leading to credible scenarios for demonstrating the successful $Q=10$, $P_{\text{fusion}}=500\text{MW}$ performance. **Advanced operation, the hybrid or advanced inductive and steady state scenarios [3]**, are now being explored in order to meet alternative missions of ITER. The **initial results [4] have indicated the potential for development of successful alternative performance with $Q=5$ in long pulse (1000s) or in steady state operation.** These results pose a significant number of questions that must be addressed for development of advance operations to the same level of confidence as achieved for the inductive baseline scenarios. **Significant issues regarding performance and the confinement improvement factor required have been raised along with the adequacy of the baseline or upgraded control actuators, diagnostics, and controllers. These control issues must be addressed as we develop concepts to be utilized by the Plasma Control System (PCS) for which a conceptual design has recently been initiated.** These control requirements will be assessed via the integrated modeling of advanced scenarios. We have begun simulations to explore both the robustness and range of operation of these hybrid and steady state scenarios. This exploration is being done with a combination of equilibria assessment for optimizing the shape evolution and with time-dependent free-boundary evolution studies to explore controllability. Initial studies of plasma control for the hybrid scenario will be presented along with an assessment of the steady-state configuration.

Modeling development of ITER scenarios with free-boundary transport for control

- Scenarios at $B_T=5.2T$ (full field) H-mode:
 - ❑ Baseline inductive: $I_p=15MA$, $Q=10$, $P_{fus}=500MW$, to 400s duration
 - ❑ Advanced inductive or hybrid: $I_p=12.5MA$, $Q=5$, 1000s duration
 - ❑ Steady-state: $I_p=9MA$, $Q=5$, steady state – likely internal transport barrier
- Low-activation: DD at $I_p=7.5MA$ and $B_T=2.56T$ (half I_p , B_T) – under development and of current interest
- Non-activation: H or He operations at reduced I_p , B_T
- Tool: CORSICA – 2D equilibrium + 1D transport predictive modeling code
Crotinger, J.A. *et al* LLNL Report UCRL-ID-126284, 1997 NTIS #PB2005-102154
 - ❑ Full free-boundary GS solutions with various transport models to evolve plasma shape, vertical position and kinetic profiles
 - ❑ Simultaneously converges free-boundary equilibrium and transport at each time step
 - ❑ Calculates sources each time step if desired (e.g. for control): NBI, EC, IC, LH
 - ❑ Coupled to Matlab/simulink environment for controller evaluation (Meyer, LLNL)
 - ❑ Modular, customizable with interruptable work flows from interpretive scripting

Recent modeling has advanced understanding of ITER performance

- Current modeling includes latest modifications to ITER systems
 - ❑ coil and first wall geometry
 - ❑ power systems and source design parameters
- Baseline inductive modeling – successful scenarios within operating space
 - ❑ [1] Kessel, C.E. *et al* Nucl. Fusion **49** (2009) 085034
 - ❑ [2] Casper, T. *et al* accepted Nuc. Fusion **51**(2011) ; in Fusion Energy 2010 (Proc. 23rd Int. Conf. Daejeon, 2010) (Vienna: IAEA) CD-ROM file ITR/P1-19
<http://www-naweb.iaea.org/napc/physics/FEC/FEC2010/html/index.htm>
- ITER tasks and efforts at the IO advanced modes: advanced inductive (hybrid) and steady-state scenarios
 - ❑ [3] Gormezano, C. *et al* Nucl. Fusion **47** (2007) S285-S336
 - ❑ [4] Kessel, C.E. *et al* in Fusion Energy 2010 (Proc. 23rd Int. Conf. Daejeon, 2010) (Vienna: IAEA) CD-ROM file ITR/P1-22 and <http://www-naweb.iaea.org/napc/physics/FEC/FEC2010/html/index.htm>
 - ❑ New effort at IO: Monaco post-doc program, Sun Hee Kim – initial results

Scenario modeling capabilities upgraded and directed toward control applications – also data for ITER tasks

- Controlled scenario development and testing
 - ❑ Free boundary with VS1 and VS3 capability
 - ❑ Connection to external controllers (simulink)
 - ❑ “gaps” to control shape (slow) and vertical position
- Studies and alternative scenarios
 - ❑ H-to-L thresholds and dynamics; ELMs
 - ❑ Controller performance
- Sources can be updated each time step for control
 - ❑ New versions of CORSICA’s monte carlo NBI (geometry) and Toray-GA for ECH/CD (version and geometry)
 - ❑ Adding/testing ICH(Toric) and LH(LSC)
 - ❑ Considering adding other source models (Oikawa, ITER)
- Transport models to be added
 - ❑ Edge model – based on EPED1
 - ❑ Bohm-gyroBohm transport (now use Coppi-Tang or GLF23)

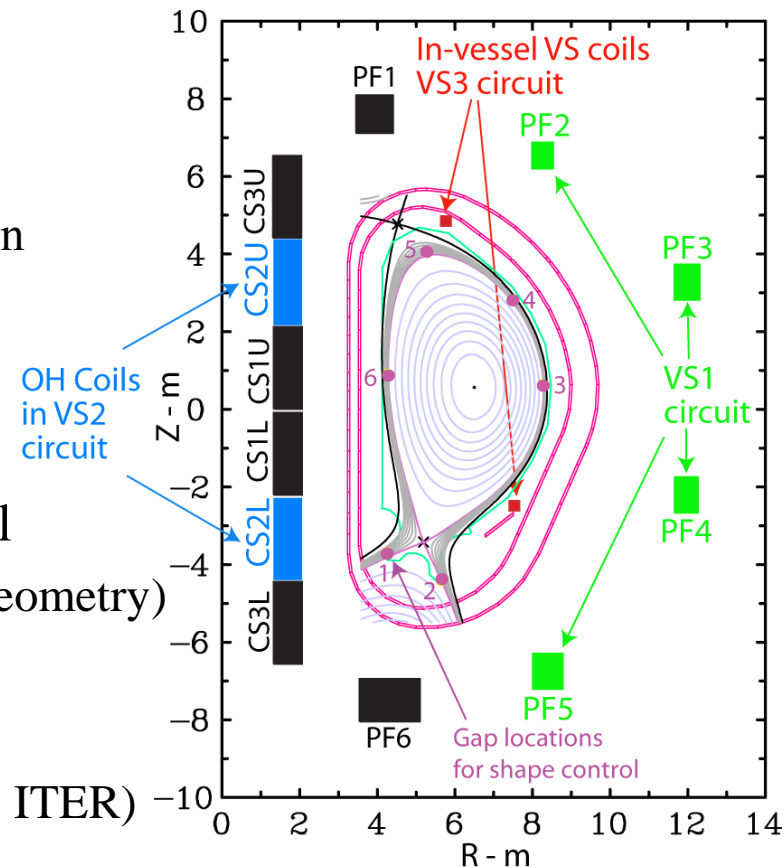

JTC-2001 controller with VS1 circuit for vertical stability control

554

T.A. Casper et al. / Fusion Engineering and Design 83 (2008) 552–556

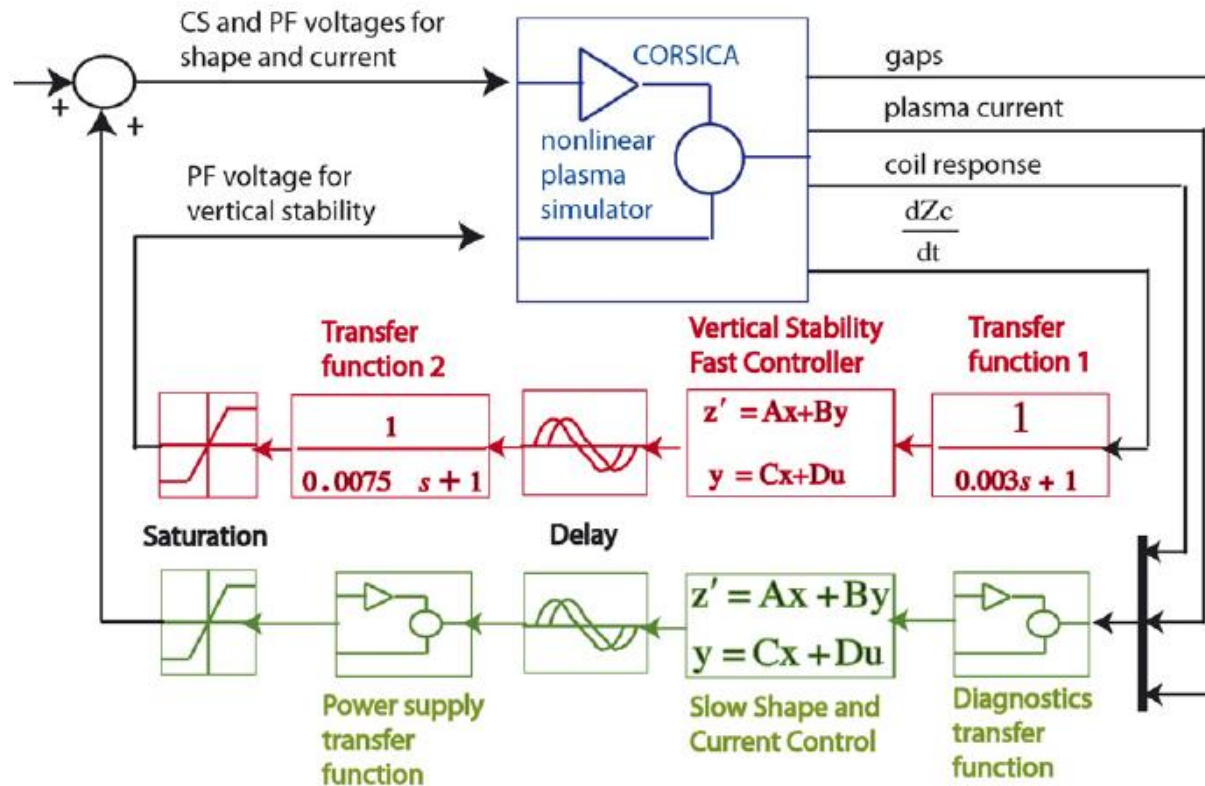
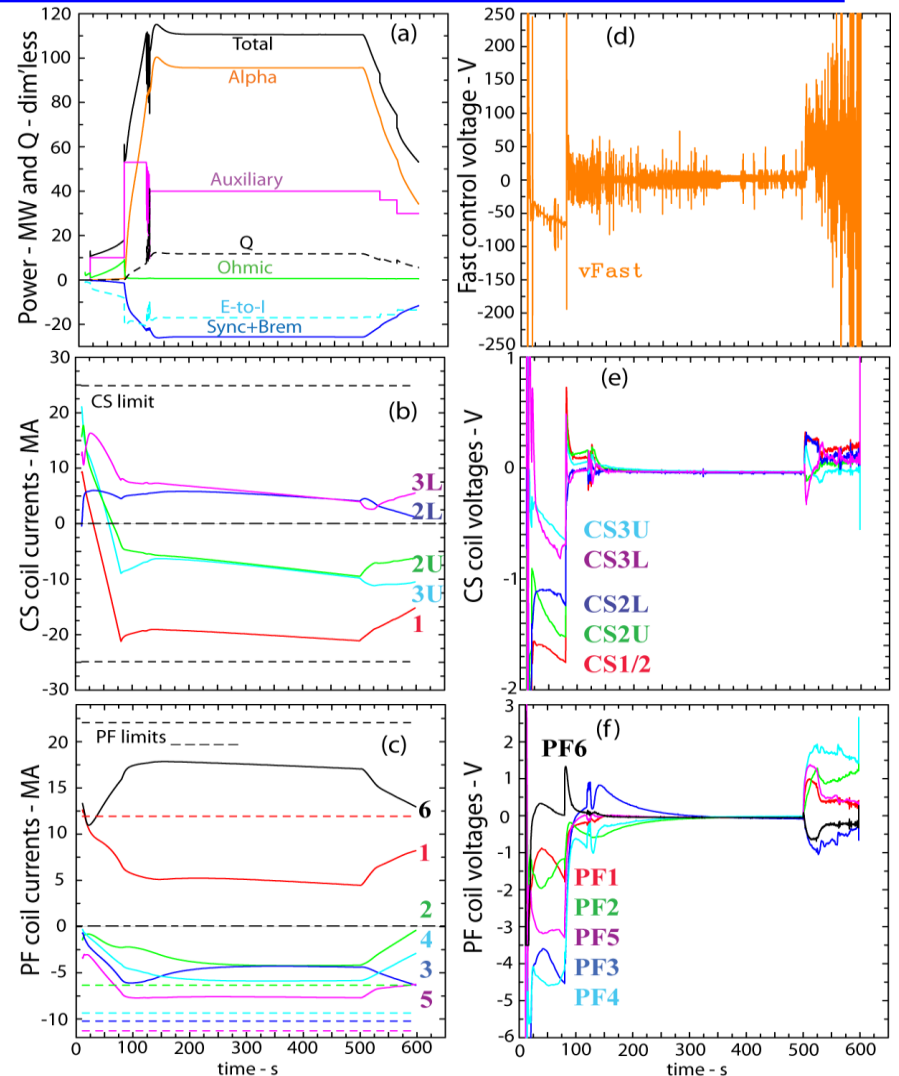
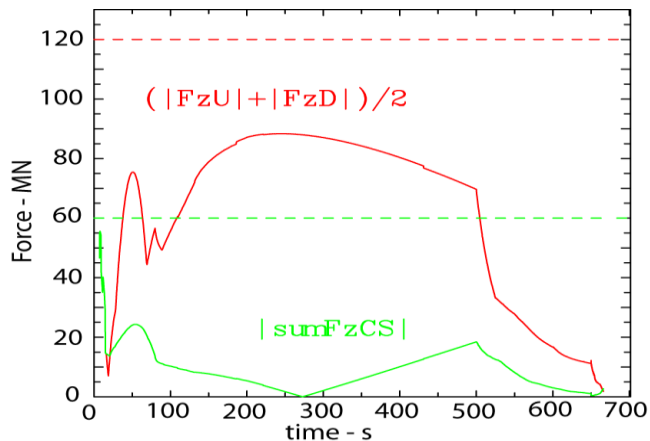

Fig. 3. Block diagram of the ITER controller used for shape and vertical stability control. The feedback loops and matrices are implemented for either Matlab-coupled control or internal to CORSICA to provide controller capability.

Feedback-controlled evolution for baseline inductive: $I_p=15\text{MA}$, $Q=10$, 400s duration burn and $P_{\text{fus}}=500\text{MW}$

- Baseline inductive simulations [2] from CORSICA, DINA, and TCS
- Coil current limits shown in (b) and (c) for all coils and forces below
- Evaluation of controllability and limits required for all operational modes



Developing a “low activation” scenario for early ITER operation: acceptable tritium production and controllable

- Operation at half plasma current, $I_p=7.5\text{MA}$, and half toroidal magnetic field $B_T=2.26\text{T}$ with the JCT-2001 controller
- Explore issues with early DD operations: performance and activation
- 15MA inductive case re-defined for 7.5MA study
 - ❑ Same input waveforms – except early heating not required for PF/CS limits
 - ❑ Same shapes – inside wall limited and full plasma shape
 - ❑ Assume H-mode access with auxiliary heating, P_{aux}
- Initial scenario developed: D as base particle source, T from reaction rates:
 - ✓ DDn: $D+D\rightarrow\text{He}^3+n^0$ at ~50%
 - ✓ DDp: $D+D\rightarrow\text{T}+p^+$ at ~50% - tritium source rate
 - ✓ DT: $D+T\rightarrow\text{He}^4+n^0$ produced T burn up
 - ✓ S_T : DDp – DT resulting T particle source rate $\rightarrow N_T(\phi)$
 - ❑ Assume no T diffusion (perfect confinement) to calculate maximum production
 - ❑ Auxiliary heating power and transport assumptions varied
 - ❑ Analytic sources and density profiles for development so far

Simulation with $P_{aux}=53\text{MW}$ of electron heating results in T particle inventory of 0.3×10^{20} after a 400s flattop pulse

- (a) Plasma current and auxiliary heating power
 - ❑ Resulting electron and ion temperatures at the magnetic axis using the C-T thermal transport model
- (b) On-axis electron density assumed (peak in $N_{GW}=.51 \times 10^{20}$)
 - ❑ Tritium density from reaction rate source: $N_T \sim N_D/400$
 - ❑ Resulting alpha heating $P_{alpha} \sim P_{aux}/500$
 - ❑ Internal inductance evolution, l_{i3} , vertical stability parameter
 - ❑ Confinement, h_{98y2} , from scaling of C-T model
- (c) Rates for nuclear reactions
 - ❑ ----- volume-integrated rate in #/s
 - ❑ *---*---* time-integrated accumulations in #
 - ❑ S is the T particle source: at $t = 500\text{s}$, the total integrated T production is $\sim .3 \times 10^{20}$ particles $\sim .15\text{mg}$

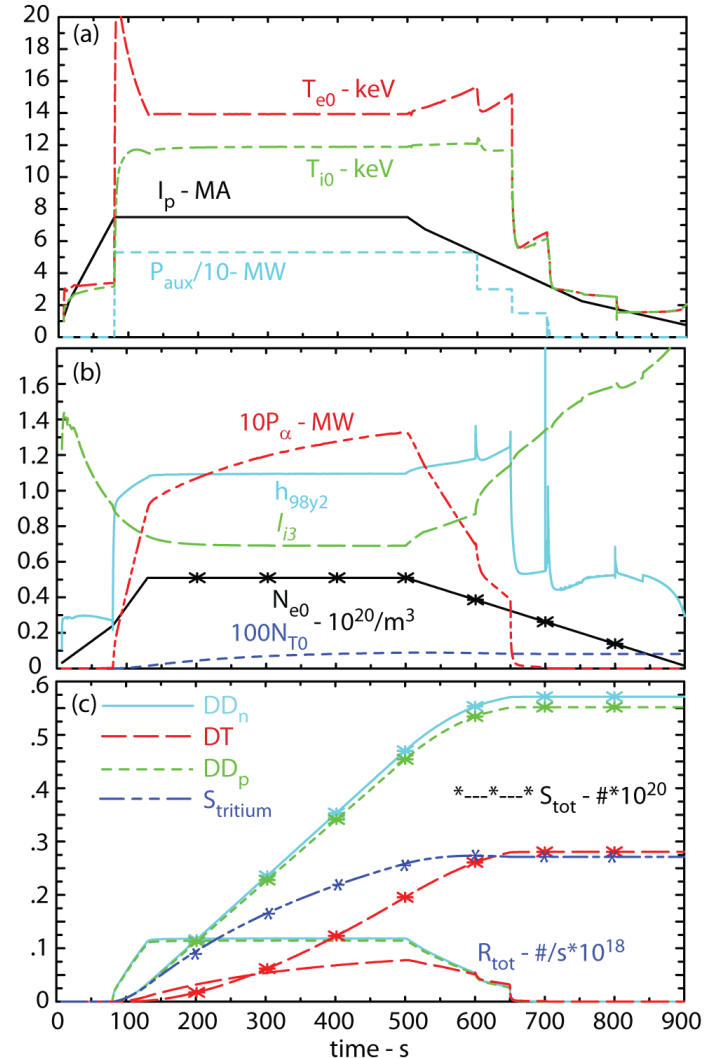

Assumed and simulated profiles at 450s for flat-top current of $I_p=7.5\text{MA}$ with $P_{\text{aux}}=53\text{MW}$

➤ (a) Input density profiles

- ❑ N_e assumed H-mode electron density profile shape (same as 15MA inductive modeling)
- ❑ N_D is the assumed **deuterium**
- ❑ $q_{\text{imp}} * N_{\text{imp}}$ is the charge-scaled (e.g. fully ionized) **impurity** assumed to be carbon at $N_C/N_D = .055 \rightarrow Z_{\text{eff}}=1.7$
- ❑ N_T is the resulting tritium density profile resulting from the T-particle reaction source rate: $N_T \sim N_D/400$

➤ (b) Response profiles using the C-T transport model

- ❑ Temperature profiles, T_e and T_i
- ❑ $\langle J_T \cdot B \rangle / \langle B_T / R \rangle$ is the total flux-surface-averaged current – sawtooth flattening
- ❑ Safety factor, q

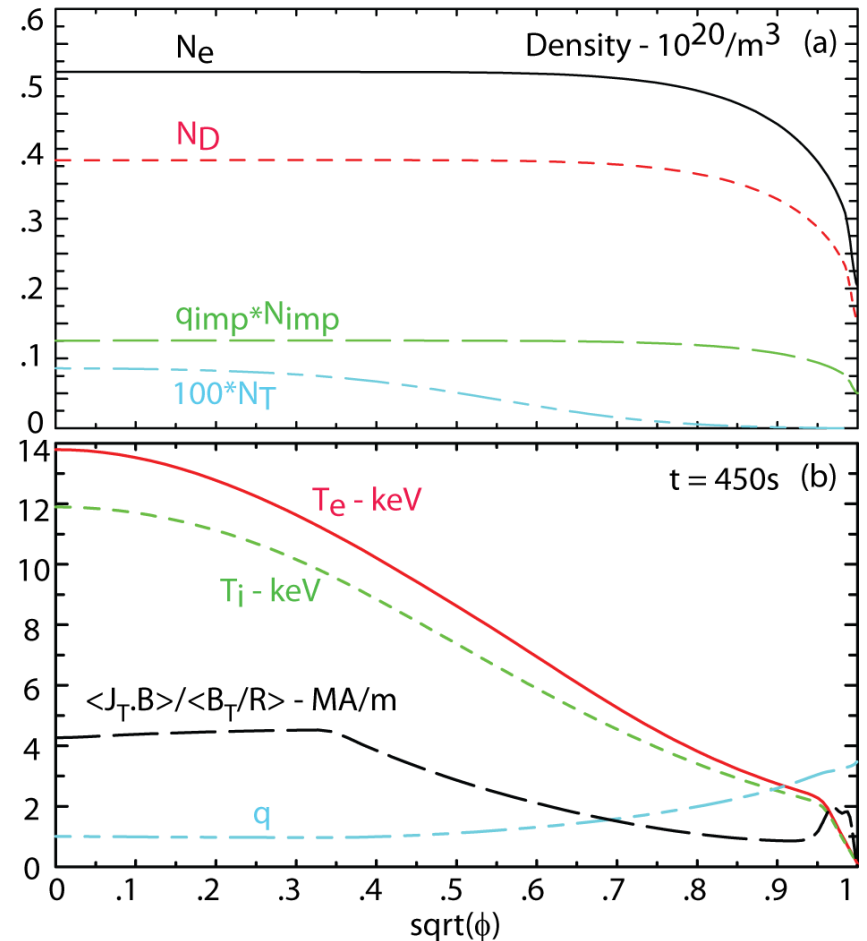

Reaction rates for plasma parameter scans indicates the weak scaling of tritium buildup

Volume integrated rates - particles/s

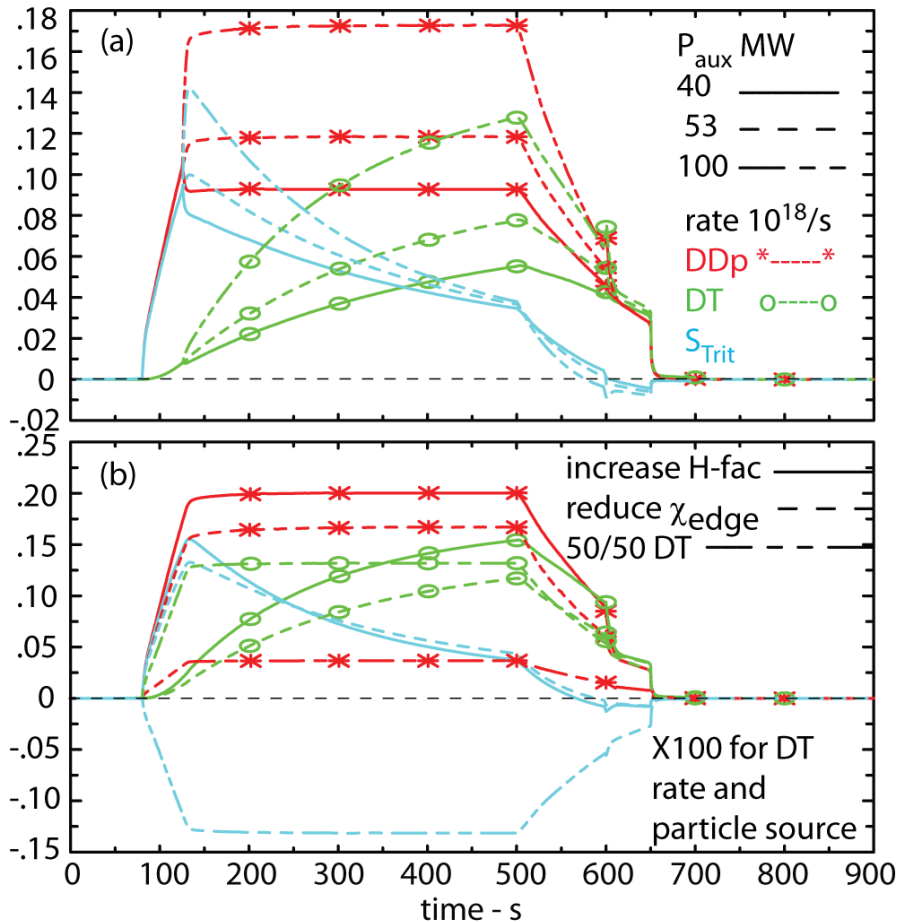

Total integrated source - particles

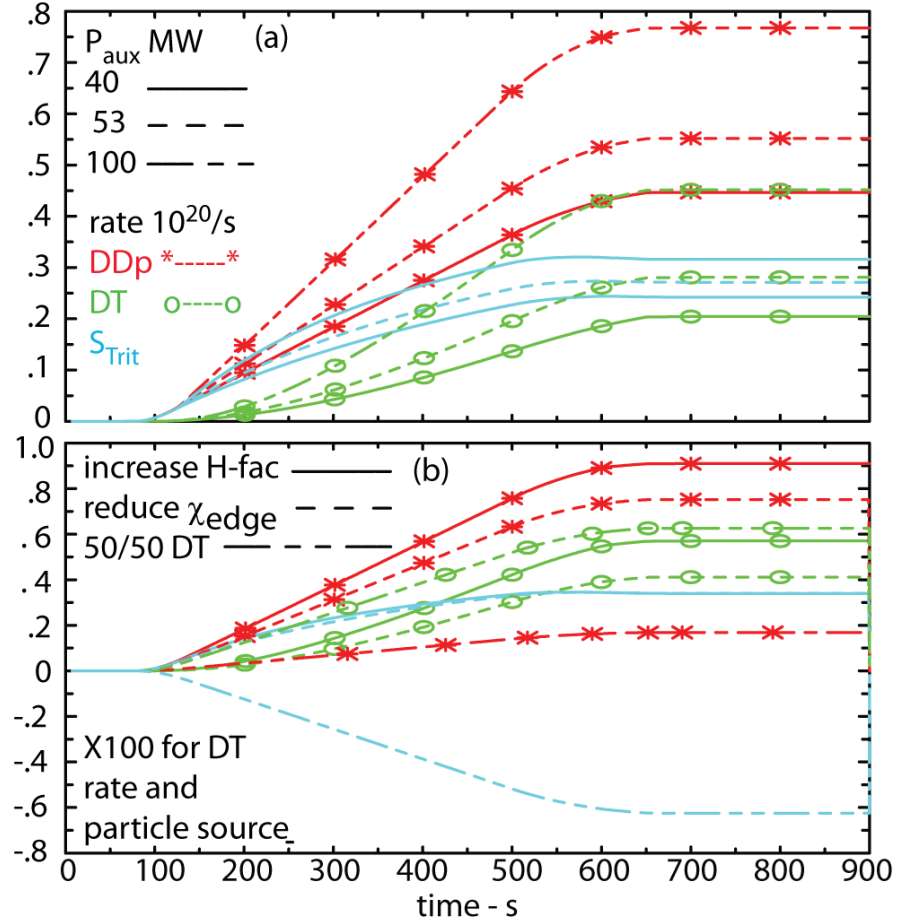

Free-boundary evolution with JCT2001 controller (from 15MA inductive scenario) maintains plasma shape and vertical position

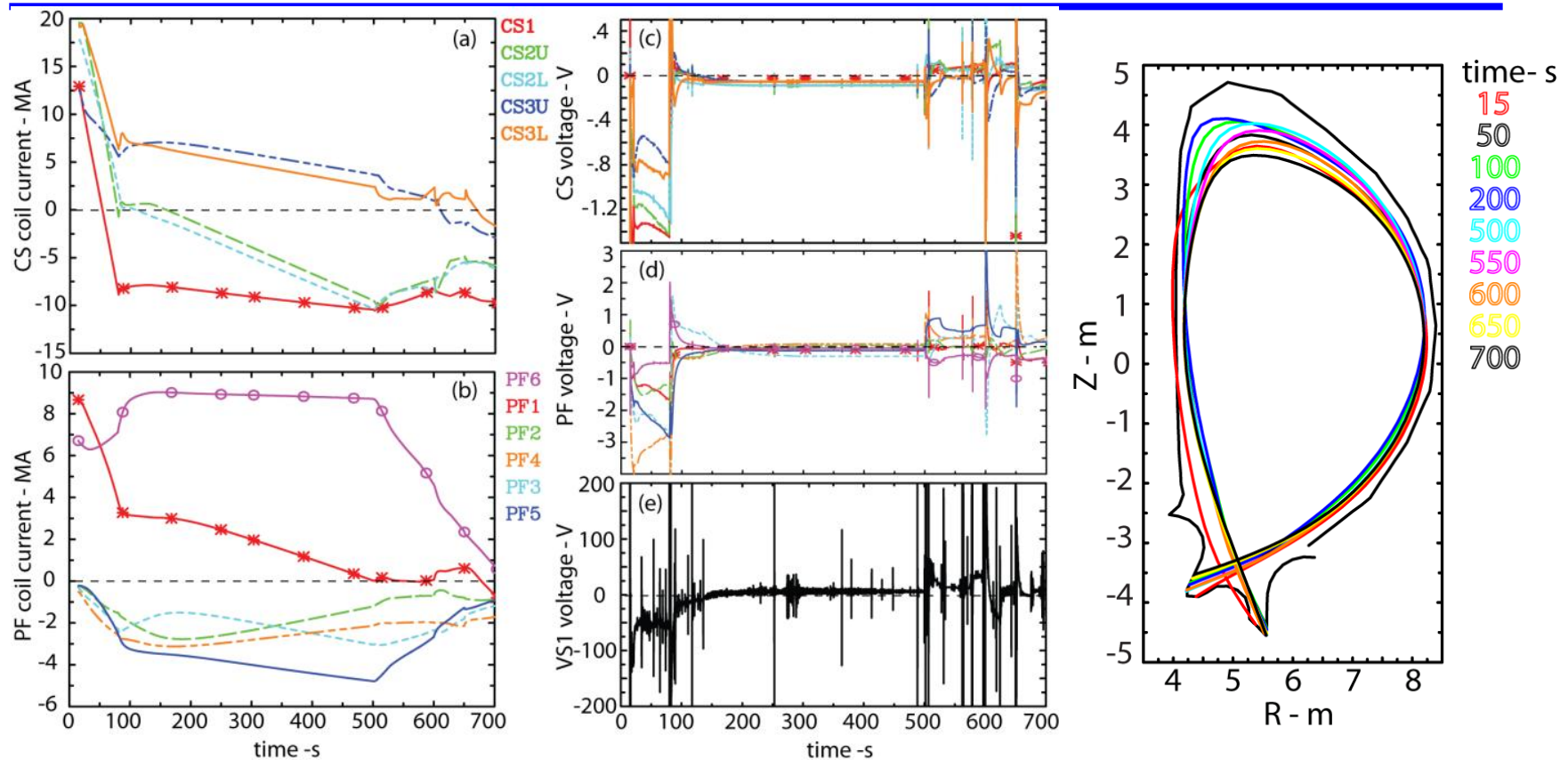

- (a) CS and (b) PF coil currents which are far from allowed limits
- (c) CS and (d) PF voltages for feedback control of plasma shape
- (e) Fast voltage applied to PF2-PF5 coils for VS1 control of vertical position

Controller capable of making the transition from inside-wall limited to diverted shapes – shape/position control needs to be optimized

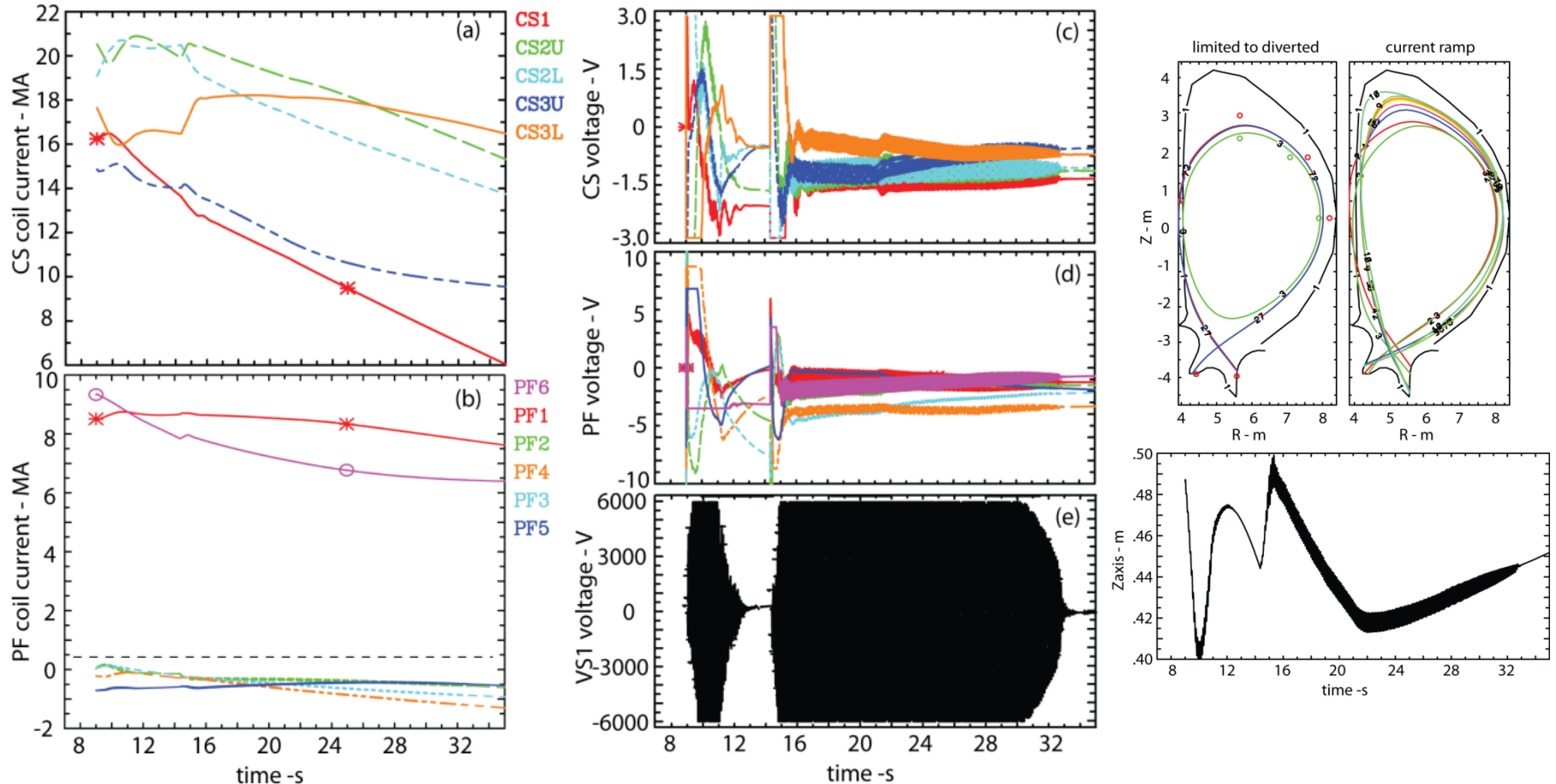

- Modification of strike point to pull shape off inside wall
- Modification of upper control gap to eliminate poor shape control at full I_p

Developing controlled hybrid scenarios with full time-dependent modeling of sources in free-boundary simulations

- Sun Hee Kim at IO funded by the Monaco post doctoral research program
- Using CORSICA code from LLNL to develop hybrid scenario (steady-state to follow)
- CORSICA source modifications - all sources can be updated each time-step for feedback control
- Running with both prescribed shape and full free-boundary controlled evolution
 - ❑ Prescribe shape: fast scenario development and feed-forward waveforms for control
 - ❑ Free-boundary with controller for shape and vertical position control
- Initial results
 - ❑ Simulations from 7s to 1200s
 - ❑ Optimizing heating and current drive sources to maintain $q_{\min} > 1$
 - ❑ Adjusting pre-magnetization to avoid current limits (pulse length)
 - ❑ Tuning early heating and current drive for access to flat-top

Prescribed boundary simulations used for hybrid mode for scenario development

- Ramp-up in 60s to flattop current of $I_p=12.5\text{MA}$ without change in pre-magnetization
- L-to-H transition at 2/3 flattop I_p : 40s, 8MA
- Impurities: Be and Ar with constant profile and concentration from programmed Z_{eff} (Lukash)
 $Z_{\text{eff}}=1.7+2.3*(N_{e0}/N_e)^{2.6}$
- Early ECH: 13.3MW after X-point formation
- Prescribed boundary for fast simulation times

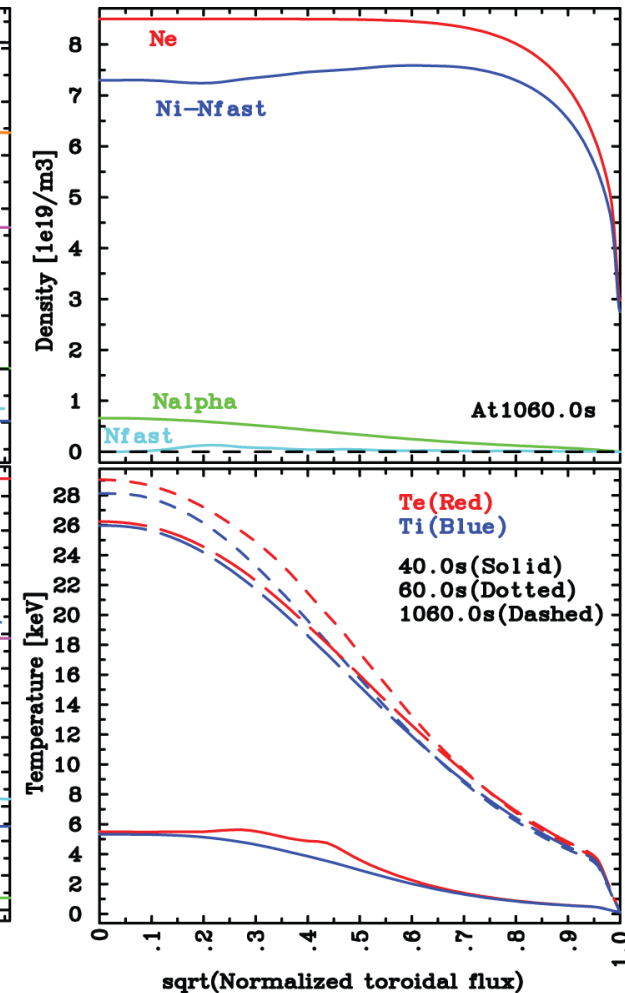
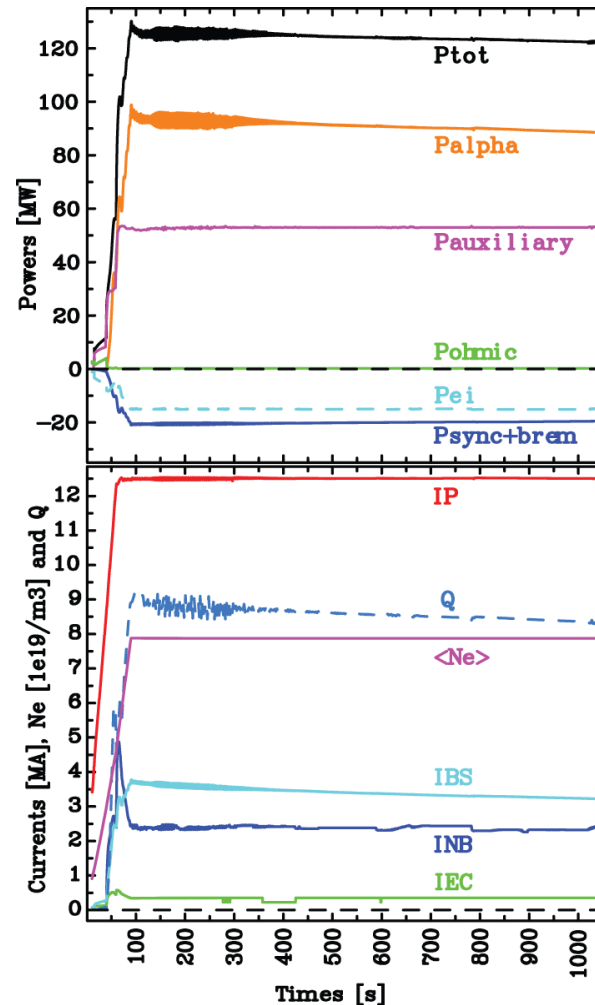

Free-boundary control simulation with computed heating and current drive from NBI and EC models

- Test case: optimizing heating and current drive
- Reference coil currents (feed-forward) obtained from prior prescribed boundary simulation
- Comparison of feed-forward currents (dashed) and controller currents (solid) in reasonable agreement
 - new method gives better control
- Late-time coil current limit violation: CS1, PF6, and PF5
 - Non-optimized shape
 - Need different pre-magnetization (e.g. Kessel)
 - Shorter flat top duration
 - Current and q-profile control

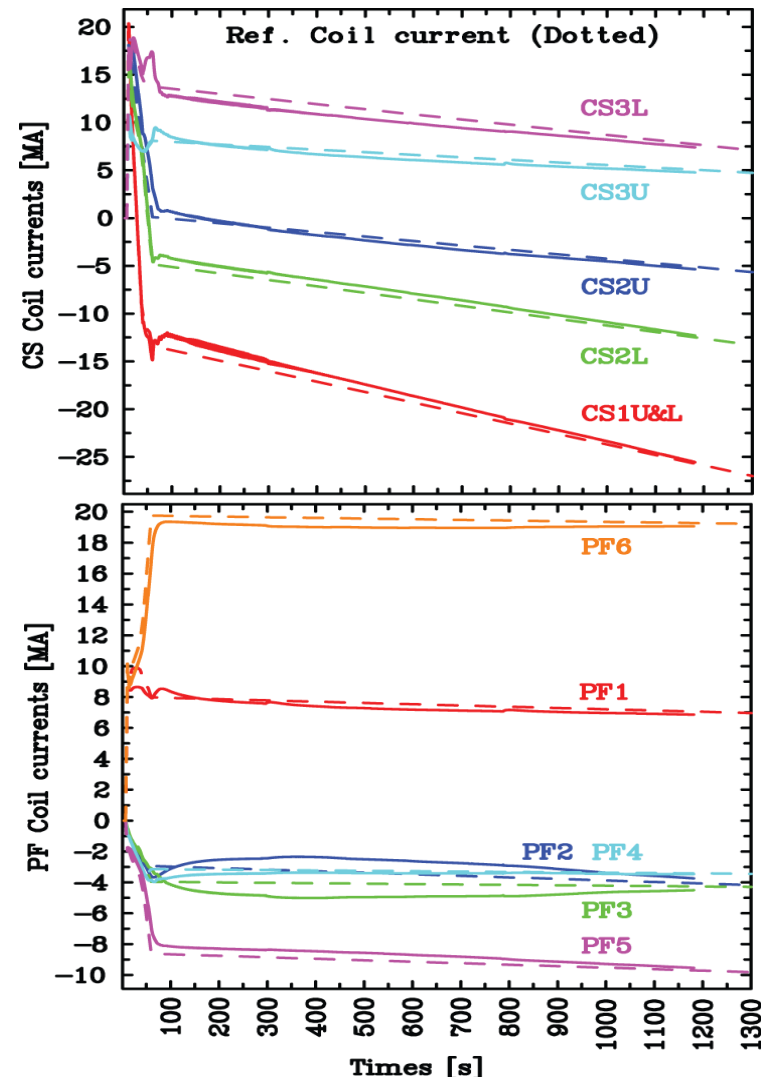

Plasma evolution actively controlled

- Shape and vertical position from ITER controller
- Active control of $H_{\text{iter98}(y,2)}$ during H-mode phase (from H-to-L to L-to-H)
- ICH power not used so high $Q \sim 9$
- Realistic sources for NBI and EC
- Current densities at 60s and 1000s shown along with q profile evolution
- Sawtooth model turned off allowing $q_{\text{min}} < 1.0$ – optimizing heating and current drive to keep $q_{\text{min}} > 1$

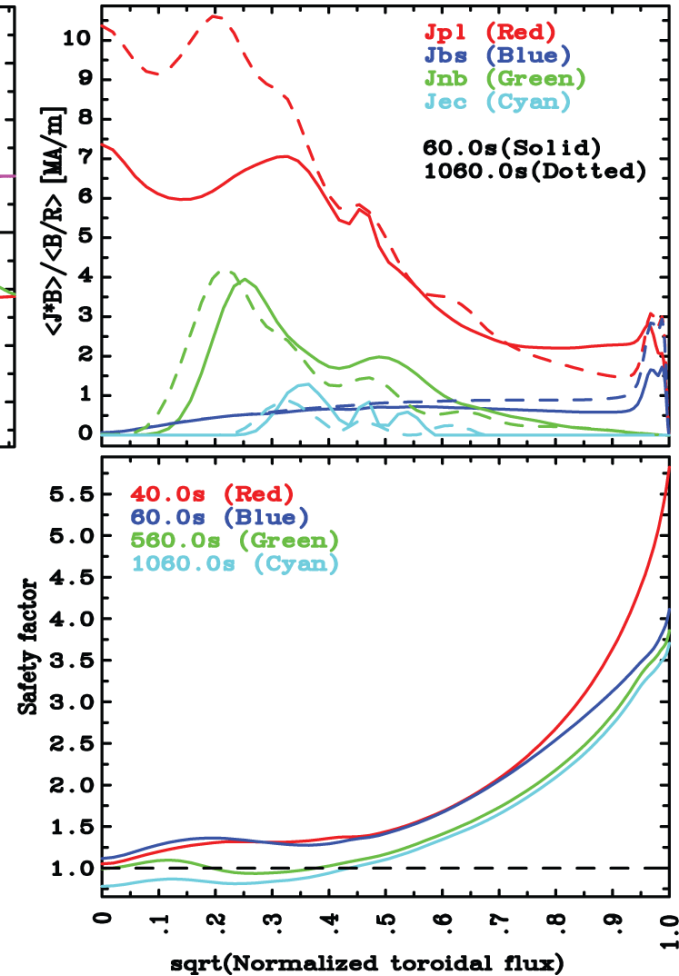
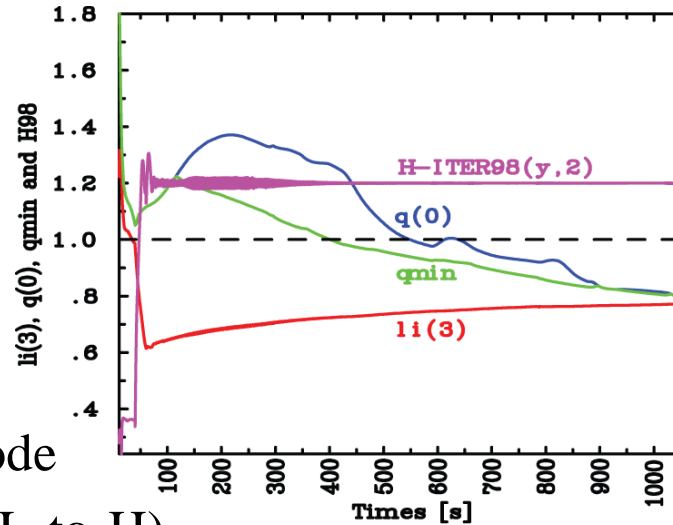

Summary/Future: the tools are in place and we are simulating a variety of controller aspects for ITER

- Controller development - simulations will support these efforts
 - ❑ New controllers have been proposed for improving ITER performance
 - ❑ The Plasma Control System (PCS) conceptual design
- Shape and vertical position
 - ❑ Significant efforts have been done for the baseline 15MA case
 - ✓ Meyer, *et al*, IAEA-TM, San Francisco June 2011 simulink/rampdown
 - ❑ This needs to be extended to the alternative scenarios
 - ✓ Advanced inductive (hybrid) is being worked on
 - ✓ The Steady-state control will be done
 - ✓ Alternatives like the low-activation scenario are being defined and developed
- Kinetic control efforts for performance
 - ❑ Feed-back control of q (current profile)
 - ❑ Temperature and stored energy control
 - ❑ Burn control
 - ❑ Stabilization of islands

